

7700

20-Channel, Differential Multiplexer Module

with Automatic CJC, Screw Terminals, and up to 50MHz Bandwidth

- 20 channels for general-purpose measurements, plus two channels to measure current
- Oversize screw terminal connection blocks are standard for easier connections
- 50MHz bandwidth
- 300V, 1A capacity for voltage channels; 60W, 125VA
- 3A capacity for current channels
- Low insertion loss of up to 50MHz
- Relay closures stored in onboard memory

Ordering Information

7700 20-Ch, Diff Mux Module w/Automatic CJC and Screw Terminals

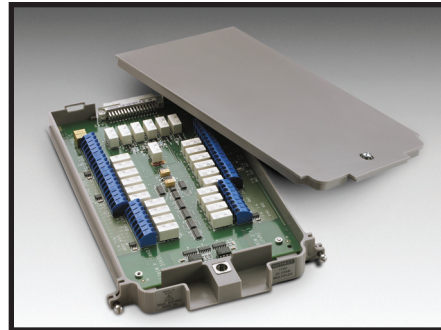

The Model 7700 plug-in module offers 20 channels of 2-pole or 10 channels of 4-pole multiplexer switching that can be configured as two independent banks of multiplexers. There are two additional protected channels for current measurements. Automatic CJC is provided so that no other accessories are required to make thermocouple temperature measurements. In addition, the Model 7700 contains latching electromechanical relays that enable signal bandwidths of up to 50MHz. The Model 7700 is ideal for RTD, thermistor, and thermocouple applications.

CAPABILITIES

CHANNELS 1-20: Multiplex one of 20 2-pole or one of 10 4-pole signals into DMM.

CHANNELS 21-22: Multiplex one of 2 2-pole current signals into DMM.

INPUTS

MAXIMUM SIGNAL LEVEL:

Channels (1-20): 300V DC or 300V rms (425V peak) for AC waveforms, 1A switched, 60W, 125VA maximum.

Channels (21-22): 60V DC or 30V rms, 3A switched, 60W, 125VA maximum.

CONTACT LIFE (typ.): >10⁵ operations at max signal level.
>10⁸ operations cold switching.

CONTACT RESISTANCE: <1Ω at end of contact life.

CONTACT POTENTIAL: <±500nV typical per contact, 1μV max.
<±500nV typical per contact pair, 1μV max.

OFFSET CURRENT: <100pA.

CONNECTOR TYPE: Screw terminal, #20 AWG wire size.

ISOLATION BETWEEN ANY TWO TERMINALS: >10¹⁰Ω,
<100pF.

ISOLATION BETWEEN ANY TERMINAL AND EARTH: >10⁹Ω,
<200pF.

INSERTION LOSS (50Ω Source, 50Ω Load):

	w/Internal DMM	w/o Internal DMM*
<0.1 dB:	1 MHz	1 MHz
<3 dB:	2 MHz	50 MHz

CROSSTALK (50Ω Load):

	w/Internal DMM	w/o Internal DMM*
10 MHz:	<-40 dB	<-40 dB
25 MHz:	**	<-25 dB

COMMON MODE VOLTAGE: 300V or 300V rms (425V peak) for AC waveforms between any terminal and chassis.

TEMPERATURE ACCURACY USING INTERNAL CJC: 1.0°C (see mainframe specification for details).

* Channels 24 and 25 are open. Refer to ROUTe:MULTIPLE command in 27XX User Manual.

** Not valid.

GENERAL

20 CHANNELS: 20 channels of 2-pole relay input. All channels configurable to 4-pole.

2 CHANNELS: 2 channels of current only input.

RELAY TYPE: Latching electromechanical.

ACTUATION TIME: <3ms.

FIRMWARE: Specified for Model 2700 rev. A01, 2701 rev. A01, and 2750 rev. A01 or higher.

ENVIRONMENTAL:

OPERATING ENVIRONMENT: Specified for 0°C to 50°C.
Specified to 80% R.H. at 35°C.

STORAGE ENVIRONMENT: -25°C to 65°C.

WEIGHT: 0.45kg (1 lb).

ACCESSORY AVAILABLE: Model 7401 Type K Thermocouple Wire, 30.5m (100 ft).

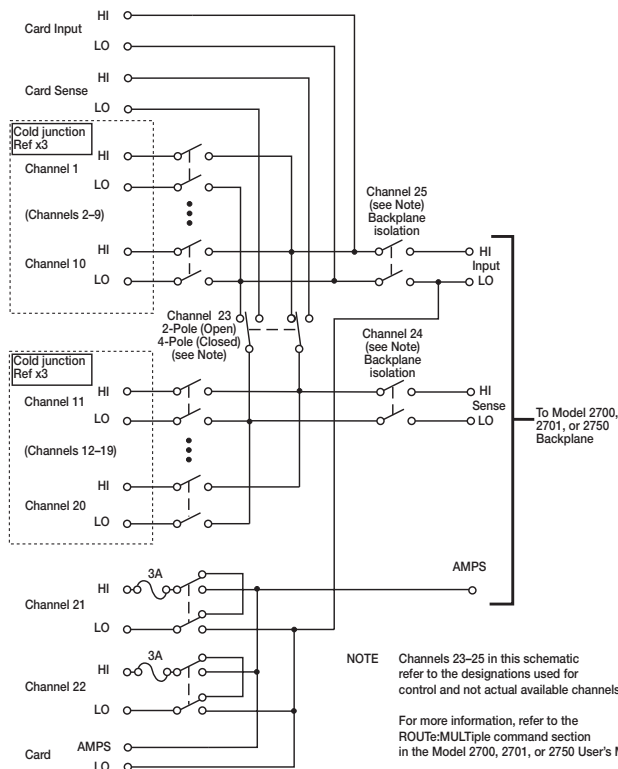

NOTE Channels 23-25 in this schematic refer to the designations used for control and not actual available channels.

For more information, refer to the ROUTe:MULTIPLE command section in the Model 2700, 2701, or 2750 User's Manual.

Channels 24 and 25 can be individually controlled using ROUTe:MULTIPLE if the module is not to be connected to the internal DMM.

1.888.KEITHLEY (U.S. only)

www.keithley.com

KEITHLEY

A GREATER MEASURE OF CONFIDENCE

Use with Integra Series Mainframes: 2700, 2701, 2750

DMMS, DATA ACQUISITION/
SWITCHING SYSTEMS